

Wood Lathe Survey	
Machine Owner	Worksite
Surveyor's Name:	Date of Survey: _____ / _____ /20____
Supervisor's Name:	Room Name or Number:
Machine Manufacturer:	
Model #:	Serial #
Supply Voltage:	Number of supply phases (circle one) <b>1 or 3</b>
Horsepower:	Full Load Amps:

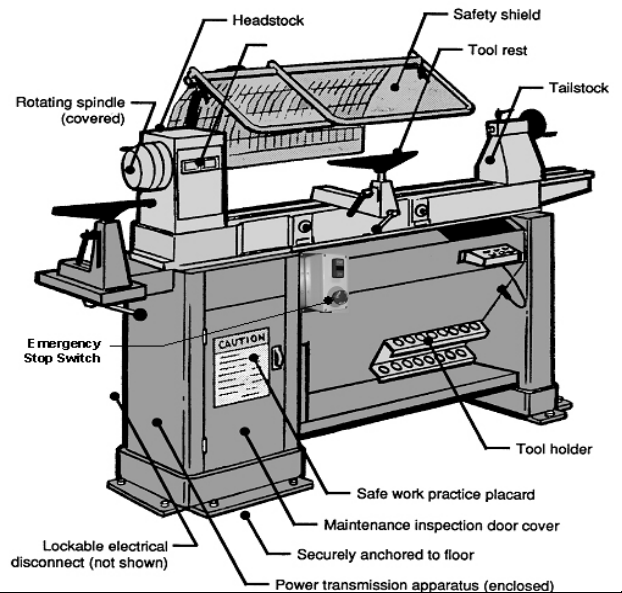

	Yes	No	N/A
1. Is the machine properly color coded?			
2. Does the machine have a safety shield which extends the entire length of the bed?			
3. Is the power transmission system guarded correctly?			
4. Is the left end of the spindle properly guarded?			
5. Does the machine have power outage protection?			
6. Does the machine have an emergency stop?			
7. Are the electrical system, wires and plug ends acceptable?			
8. Is the worklight properly protected against impact?			
9. Is the machine secured to prevent walking or moving?			
10. Does the machine have a high-friction coating at the operator's position on the floor?			

Notes

---



---



---



---



---



---



---