

Vertical Mill Survey

Machine Owner	Worksite
Surveyor's Name:	Date of Survey: ____/____/20____
Supervisor's Name:	Room Name or Number:
Machine Manufacturer:	
Model #:	Serial #
Supply Voltage:	Number of supply phases (circle one) 1 or 3
Horsepower:	Full Load Amps:

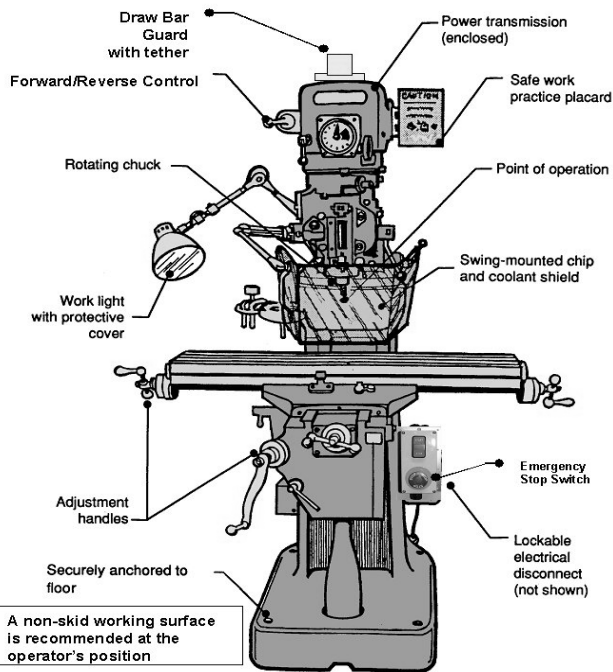

	Yes	No	N/A
1. Is the power transmission system properly guarded?			
2. Is the draw bar properly covered?			
3. Is the machine properly color-coded?			
4. Does the machine have a chip/coolant shield?			
5. Are the electrical system, wires and plug ends compliant?			
6. Are the work lights properly protected?			
7. Can the machine be securely isolated from its power source?			
8. Is the machine secured to prevent walking or moving?			
9. Does the machine have a high-friction coating at the operator's position on the floor?			

Notes
