

Pedestal / Bench Grinder Survey	
Machine Owner	Worksite
Surveyor's Name:	Date of Survey: _____ / _____ /20____
Supervisor's Name:	Room Name or Number:
Machine Manufacturer:	
Model #:	Serial #
Supply Voltage:	Number of supply phases (circle one) 1 or 3
Horsepower:	Full Load Amps:

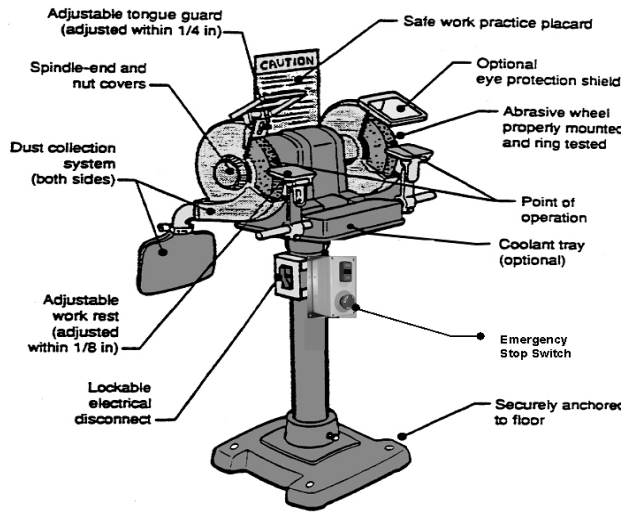

	Yes	No	N/A
1. Is the machine properly color coded?			
2. Is the worklight properly protected against impact?			
3. Are the chip shields clean and in working order?			
4. Are tool rests adjusted at 1/8" from the wheel and tongue guards 1/4" from wheel?			
5. Are the electrical system wires and plug ends acceptable?			
6. Can the machine be securely isolated from its power source?			
7. Does the machine have proper power outage protection?			
8. Does the machine have a proper emergency stop?			
9. Does machine have a proper dust collection system?			
10. Is the coasting time after shutdown acceptable?			
11. Does the machine have a high-friction coating at the operator's position on the floor?			
12. Is the machine secured to prevent walking or moving?			

Notes
