

Drill Press Survey	
Machine Owner	Worksite
Surveyor's Name:	Date of Survey: ____/____/20____
Supervisor's Name:	Room Name or Number:
Machine Manufacturer:	
Model #:	Serial #
Supply Voltage:	Number of supply phases (circle one) 1 or 3
Horsepower:	Full Load Amps:

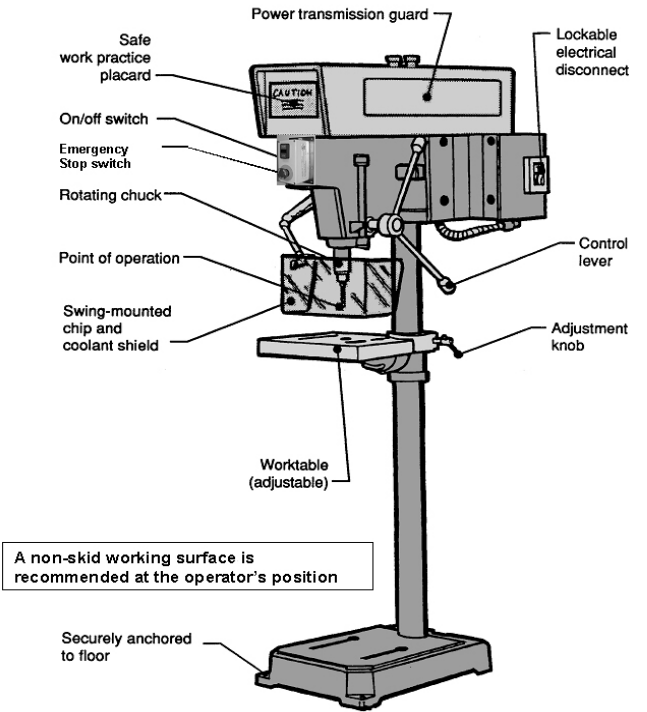

	Yes	No	N/A
1. Is the machine properly color-coded?			
2. Are the openings at the top of the drill press properly guarded?			
3. Is the area around the motor properly guarded?			
4. Does the machine have all OEM knobs, rods, or handles?			
5. Does the machine have a proper chip shield?			
6. Are the electrical system, wires and plug ends acceptable?			
7. Does the machine have proper power outage protection?			
8. Does the machine have a proper emergency stop?			
9. Can the machine be securely isolated from its power source?			
10. Is the worklight properly protected against impact?			
11. Does the machine have a high-friction coating at the operator's position on the floor?			
12. Is the machine secured to prevent walking or moving?			

Notes
