

Vertical Band Saw	
Employer	Worksite
Surveyor's Name:	Date of Survey: ____ / ____ /20____
Supervisor's Name:	Room Name or Number:
Machine Manufacturer:	
Model #:	Serial #
Supply Voltage:	Number of supply phases (circle one) <b>1 or 3</b>
Horsepower:	Full Load Amps:

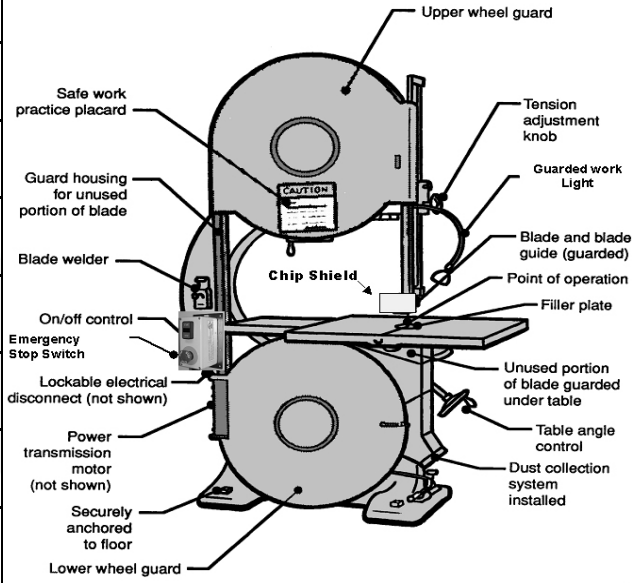

	Yes	No	N/A
1. Is the machine properly color-coded?			
2. Are the door locks and latches functional?			
3. Does the machine have a chip shield?			
4. Is the unused portion of the blade guarded above the work table?			
5. Is the unused portion of the blade guarded below the work table?			
6. Is the machines table insert in good condition?			
7. Does the machine have a lower blade guard?			
8. Are the electrical system, wires and plug ends acceptable?			
9. Does the machine have an emergency stop?			
10. Does the machine have power outage protection?			
11. Is the coasting time after shutdown acceptable?			
12. Is the worklight properly protected against impact?			
13. Does the machine have a high-friction coating at the operator's position on the floor?			
14. Is the machine secured to prevent walking or moving?			

---



---



---



---



---



---



---



---